

Operators Manual

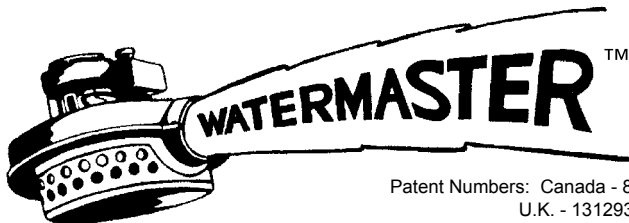

Model 706-6 Self-Priming Floating Pump

Patent Numbers: Canada - 869793; U.S.A. - 3762557, 3619075
U.K. - 1312936; Mexico - 121623



Manufactured by:

G & S SALES LTD.

Box 40, Dilke, SK Canada S0G 1C0

Ph: (306) 488-4334

Fax: (306) 488-4337

PH: 1-800-267-0006

Fill Out Warranty Card on Back

website: www.watermasterpumps.com

e-mail: info@gssales.ca

WARRANTY

G & S Sales Ltd. warrants the WATERMASTER pump to be free from defects in material and workmanship for a period of one year from the date of delivery to the original farm purchaser, 90 day warranty for commercial use and no warranty if machine is used for rental purposes. Warranty is not transferable unless authorized by G & S Sales Ltd.

The engine is warranted by the engine manufacturer. Please refer to the Engine Owner's Manual for engine warranty information.

Pump Warranty and Return of Parts

If a pump part fails or malfunctions return the part to G & S Sales Ltd. for inspection and warranty considerations.

No parts may be returned without first getting approval from G & S Sales Ltd. After receiving approval, the part(s) must be returned within 30 days after issuance of approval. All transportation charges must be prepaid. Part(s) returned and accepted in accordance with the above conditions will be credited on the basis of the prices paid at time of shipment.

Engines Warranty and Service

To secure warranty or service for the engine refer to the Engine Owner's Manual.

Replacement engines are available from G & S Sales Ltd.

Serial Number Location

The serial number is stamped into the top of the transmission – opposite the transmission fill and drain plug.

CAUTION

**Before attempting to operate the WATERMASTER Pump, read carefully and understand all instructions contained in this manual and the Engine Operator's Manual.
Watermaster is intended for outdoor use only.**

Before Starting

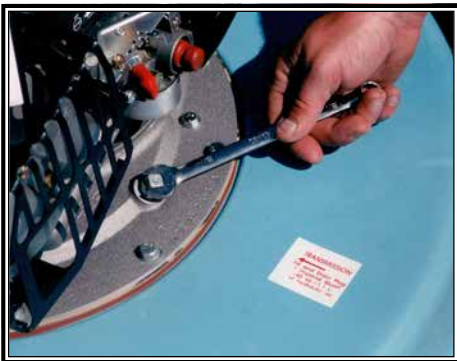

Your WATERMASTER Pump is shipped dry. Oil must be added to the pump's transmission and the engine crankcase.

Add 40 oz. or 1.1L of oil to the transmission. Use hydraulic oil or 30 mineral oil. In colder weather a lighter oil should be used in the transmission.

Refer to the Engine Operator's Manual for engine oil and fuel recommendations. Do no spill gas on pump. If you do, wipe it up.

For easier starting we suggest that you start the pump on shore and let it run till it warms up. After it has warmed up shut the engine off, float the pump on the water then restart the engine.

Connecting the hose to the pump



- 1) Double the hose back about 16" (40 cm) 2) Place the "O" Ring, made from plastic cable, between the folds.



- 3) Push the "O" Ring up to the end of the hose. 4) Connect to pump by pushing the "O" Ring into the outlet then pull hose back to let the "O" Ring rest against the housing.

Anchoring the Hose



To prevent the empty hose from being twisted and blown on windy days secure the hose by placing wire loops over the hose and inserting the ends of the wire into the ground. The wire hoops should be used every 10 to 15 ft. (3 to 4.5 m). Any stiff wire can be used, including coat hangers.

Connecting 2 Hoses

To connect 2 hoses, for longer runs, simply insert the last 5 ft. (1.5 m) of hose from the pump into the next hose. The water pressure will hold the 2 hoses together or use a 6" coupler to connect hoses - Part No. WAT42

Reinforcing the Hose

In high lift or long distance pumping situations the hose should be doubled for the first 50' to 100' (15-30 m) from the pump.

PUMP

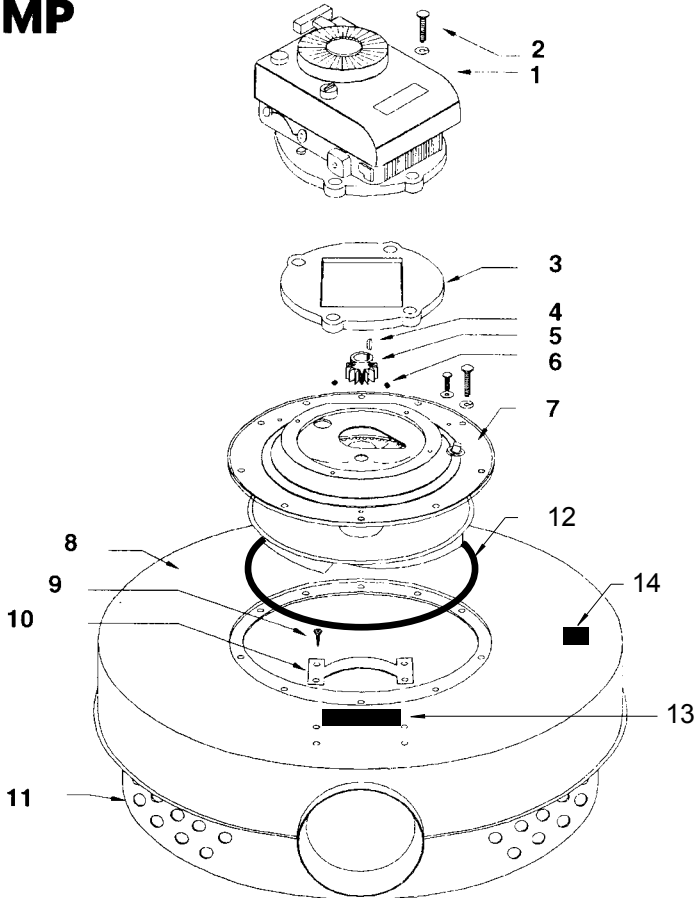

ITEM #	PART#	DESCRIPTION
1	WAT1	Watermaster Motor
2	WAT17	Bolt (x4)
3	WAT75	Motor Gasket (Kawasaki) or Silicone
4	WAT26	Half-Moon Key
5	WAT6	Pinion Gear (13 Tooth)
6	WAT27	Set Screw 5/16" x1/4"
7	WAT29	Complete Transmission
8	WAT2	Pump Housing (no motor or Transmission)
9	WAT25	Handle Screws (x8)
10	WAT23	Handle (x2)
11	WAT33	Fiberglass Screen with 1" Holes
12	WAT14	Foam Gasket
13	WAT63	Decal
14	WAT63.1	Oil Fill Decal
	WAT34	400 ft roll 6" dia. hose (18 - 20 mil)
	WAT35	Soaker Hose 200 Ft. Roll
	WAT37	Patch Tape
	WAT36	6" O-Ring Coupler
	WAT43	200 Ft. Roll 18 Mil Hose Reg 6" Dim.

TRANSMISSION

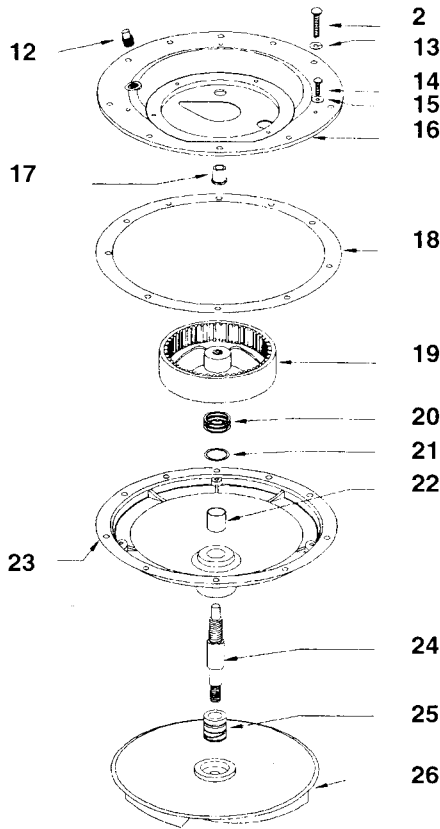

ITEM #	PART#	DESCRIPTION
2	WAT17	Bolt (x10)
12	WAT45	Fill & Drain Plug
13	WAT51	Lockwasher (x10)
14	WAT20	Bolt (x3)
15	WAT21	Flat Washer (x3)
16	WAT3	Engine Mount Plate
17	WAT15	Gasket
18	WAT5	Ring Gear 50 Teeth
19	WAT8	Thrust Bearing
20	WAT13	Shim
21	WAT11	Main Bushing
22	WAT4	Bottom Transmission Housing
23	WAT7	Drive Shaft
24	WAT9	Rotary Seal
25	WAT9	Rotary Seal
26	WAT9	Impeller

Larger Fuel Tank

A larger gas tank can be used with the WATERMASTER Pump. A 2 to 5 gal. (9 - 22.7 L) tank can be placed on shore with a gravity fed hose connected to the carburetor on the engine. The existing gas tank will have to be disconnected to connect the new fuel line.

Maintenance

- Change transmission oil at the beginning of every season in case of condensation build up.
- For engine maintenance refer to the Engine Operator's Manual.

NOTE: We have found that if you change the oil in the engine every 6 to 8 hours, you should increase the life of your engine. If you use a larger fuel tank it should be sized to operate the engine no more than 8 hours so you can change the oil when you refuel.

Storage

When you are storing the WATERMASTER Pump drain the fuel tank, oil the carburetor linkage and put oil into the cylinder head of the engine.

Trouble Shooting

<u>Problem</u>	<u>Cause</u>	<u>Solution</u>
Pump does not sit level in water.	Twisted hose	At the pump, turn the hose in the direction the pump is leaning.
Leaky hose	Pin holes or tear in hose	Repair with patching tape
Hose bursting at pump	Too high a lift	Double up hose at pressure points up to 100' (30 meters) or more
Milky coloured oil coming out of transmission	Seal failure on transmission	Replace seal
Engine is hard to start	Carburetor not set properly	See engine manual
	Fouled spark plug	See engine manual and use unleaded gas

